



English

Original Instructions

# Installation, Operation and Maintenance Instructions

X Range

# Spares & Service Contact Details

## Mono UK

<b>Spares</b>	+44 (0)161 214 2380 (direct line 8.15 am – 5.00 pm)
<b>E-mail</b>	spares@mono-pumps.com
<b>Service</b>	+44 (0)161 214 2390 (direct line 8.15 am – 5.00 pm)
<b>E-mail</b>	customerservices@mono-pumps.com
<b>Service</b>	+44 (0)161 339 9000 (24 hrs)

## Mono Australia

	<b>Telephone</b>	<b>Facsimile</b>
<b>Melbourne</b>	(03) 9580 5211	(03) 9580 9036
<b>Sydney</b>	(02) 9521 5611	(02) 9542 3649
<b>Brisbane</b>	(07) 3350 4582	(07) 3350 3750
<b>Adelaide</b>	(08) 8447 8333	(08) 8447 8373
<b>Perth</b>	(08) 9479 0444	(08) 9479 0400
<b>Darwin</b>	(08) 8984 3099	(08) 8947 0540
<b>Tasmania</b>	0417 345 814	(03) 6330 2051
<b>E-mail</b>	ozsales@mono-pumps.com	

## Mono New Zealand

<b>Spares &amp; Service</b>	+64 (0)9 829 0333
<b>E-mail</b>	info@mono-pumps.co.nz

## Monoflo USA

<b>Spares &amp; Service</b>	+1 713 466 7999
<b>E-mail</b>	inquire@monoflo.com

## Monoflo South America

<b>Spares &amp; Service</b>	+54 4296 8997	+54 4284 0323
<b>E-mail</b>	inquire@monoflo.com	

## Mono China

	<b>Telephone</b>	<b>Facsimile</b>
<b>Beijing</b>	+86 (0) 10 6461 1115	+86 (0) 10 8486 8481
<b>Shanghai</b>	+86 (0) 21 5915 7168	+86 (0) 21 5915 6863
<b>E-mail</b>	monoshanghai@nov.com	

# ATEX Warning Statements

## PUMPS AND PUMP UNITS

Where a pump or pump unit is to be installed in a potentially explosive atmosphere ensure that this has been specified at the time of purchase and that the equipment has been supplied accordingly and displays an ATEX nameplate or is supplied with a certificate of conformity. If there is any doubt as to the suitability of the equipment please contact Mono Pumps Limited before commencing with installation and commissioning.

Process liquids or fluids should be kept within specified temperature limits otherwise the surface of pump or system components may become an ignition source due to temperature rises. Where the process liquid temperature is less than 90°C the maximum surface temperature will not exceed 90°C provided the pump is installed, operated and maintained in accordance with this manual. Where the process fluid temperature exceeds 90°C the maximum surface temperature will be equal to the maximum process fluid temperature.

Cavities that could allow the accumulation of explosive gases, such as under guards, should where possible, be designed out of the system. Where this is not possible they should be fully purged before any work is carried out on the pump or system.

Electrical installation and maintenance work should only be carried out by suitably qualified and competent persons and must be in accordance with relevant electrical regulations.

All electrical equipment, including control and safety devices, should be suitably rated for the environment in to which they are installed.

Where there may be a risk of an accumulation of explosive gases or dust non-sparking tools should be used for installation and maintenance.

In addition to causing permanent damage to the stator, dry running of the pump could generate a rapid rise in the temperature of the stator tube or barrel, which could become an ignition source. It is therefore essential that a dry run protection device be fitted. This must shut the pump down immediately should a dry run situation occur. Details of suitable devices are available from Mono Pumps Limited.

To minimise the risk of sparking or temperature rises due to mechanical or electrical overload the following control and safety devices should be fitted in addition to a dry run protection system. A pressure relief system whereby the pump can not generate pressures in excess of the maximum rated pressure or an over pressure device which should shut the pump down when the maximum discharge pressure is exceeded. A control system that will shut the pump down if the motor current or temperature exceed specified limits. An isolator switch that will disconnect all electrical supply to the motor and ancillary electrical equipment and be capable of being locked in the off position. All control and safety devices should be fitted, operated and maintained in accordance with the manufacturer's instructions. All valves on the system should be open when the pump is started otherwise serious mechanical overload and failure may result.

It is important that the pump rotates in the direction indicated on the nameplate. This must be checked on installation and commissioning and after any maintenance has been carried out. Failure to observe this may lead to dry running or mechanical or electrical overload.

# ATEX Warning Statements

When fitting drives, couplings, belts, pulleys and guards to a pump or pump unit it is essential that these are correctly fitted, aligned and adjusted in accordance with the manufacturer's instructions. Failure to do so may result in sparking due to unintended mechanical contact or temperature rises due to mechanical or electrical overload or slipping of drive belts. Regular inspection of these parts must be carried out to ensure they are in good condition and replacement of any suspect part must be carried out immediately.

Mechanical seals should be suitably rated for the environment. The seal and any associated equipment, such as a flushing system, must be installed, operated and maintained in accordance with the manufacturer's instructions.

Where a packed gland seal is fitted this must be correctly fitted and adjusted. This type of seal relies on the process liquid to cool the shaft and packing rings so a constant drip of liquid from the gland section is required. Where this is undesirable an alternative seal type should be fitted.

Failure to operate or maintain the pump and ancillary equipment in line with the manufacturer's instructions may lead to premature and potentially dangerous failure of components. Regular inspection, and where necessary replacement, of bearings and lubrication is essential.

The pump and its components have been designed to ensure safe operation within the guidelines covered by legislation. Accordingly Mono Pumps Limited have declared the machine safe to use for the duty specified as defined by the Declaration of Incorporation or Conformity that is issued with this instruction manual.

The use of replacement parts that are not manufactured by or approved by Mono Pumps Limited may affect the safe operation of the pump and it may therefore become a safety hazard to both operators and other equipment. In these circumstances the Declaration provided will become invalid. The guarantee referenced on the Terms and Conditions of Sale will also be invalidated.

# Index

<b>SECTION 1</b>	<b>INSTALLATION</b>
	<b>START-UP PROCEDURE</b>
	<b>ASSEMBLY AND DISMANTLING ADVICE</b>
<b>SECTION 2</b>	<b>FAULT FINDING</b>
<b>SECTION 3</b>	<b>DRAWING REFERENCE NUMBERS</b>
	<b>PUMP CODING SHEET</b>
<b>SECTION 4</b>	<b>DISMANTLING AND ASSEMBLY DIAGRAMS</b>
	<b>EXPLODED VIEWS</b>
<b>SECTION 5</b>	<b>TORQUE TIGHTENING FIGURES</b>

## EC Declaration as defined by Machinery Directive 2006/42/EC.

The following harmonised standards are applicable: BS EN 809, BS EN ISO 12100 Parts 1 & 2

### EC Declaration of Incorporation

This declaration is only valid when partly completed machinery has been supplied.

In this case, the machinery meets the requirements of the said directive and is intended for incorporation into other machinery or for assembly with other machinery in order to constitute relevant machinery as defined by the said directive including any amendments, which are valid at the time of supply.

#### **IMPORTANT**

This machinery must not be put into service until the relevant machinery into which it is to be incorporated has been declared in conformity to the said directive.

This declaration is only valid when the machinery has been installed, operated and maintained in accordance with these instructions and safety guidelines contained within as well as instructions supplied for equipment assembled with or intended for use with this equipment.

### EC Declaration of Conformity

This declaration is not valid for partly completed machinery has been supplied.

In this case the machinery meets the requirements of the said directive including any amendments which are valid at the time of supply.

We further declare that, where applicable, said machinery also meets the requirements of:

The EMC Directive 2004/108/EC  
The Low Voltage Directive 2006 /95/E  
The Pressure Equipment Directive 97/23/EC  
The Outdoor Noise Directive 2005/88/EC  
The Drinking Water Directive 99/83/EC

#### **IMPORTANT**

This declaration is only valid when the machinery has been installed, operated and maintained in accordance with these instructions and safety guidelines contained within as well as instructions supplied for equipment assembled with or intended for use with this equipment.



**Mr C. Q. Griffiths - Engineering Services Manager.  
for Mono Pumps Limited, Martin Street, Audenshaw,  
Manchester England, M34 5JA**

# Installation, Operation & Maintenance Instructions

## INSTALLATION

### 1.1 INSTALLATION AND SAFETY RECOMMENDATIONS

In common with other items of process plant a pump must be installed correctly to ensure satisfactory and safe operation. The pump must also be maintained to a suitable standard. Following these recommendations will ensure that the safety of personnel and satisfactory operation of the pump is achieved.

#### 1.2.1. GENERAL

When handling harmful or objectionable materials, adequate ventilation must be provided in order to disperse dangerous concentrations of vapours. It is recommended that wherever possible, Mono pumps should be installed with provision for adequate lighting, thus ensuring that effective maintenance can be carried out in satisfactory conditions. With certain product materials, a hosing down facility with adequate draining will simplify maintenance and prolong the life of pump components.

Pumps operating on high temperature duties should be allowed to cool sufficiently before any maintenance is carried out.

#### 1.2.2. SYSTEM DESIGN & INSTALLATION

At the system design stage, consideration must be given to provision of filler plugs, and the installation of isolating valves.

#### i. HORIZONTAL MOUNTING

Pumps are normally installed in a horizontal position, mounted on a flat surface. If inclined or vertical installation is required, check with Mono Pumps Limited.

#### 1.3.1 HANDLING



During installation and maintenance, attention must be paid to the safe handling of all items. Where a pump or its components weigh in excess of 20 kg (45lb) it is recommended that suitable lifting tackle should be used to ensure that personal injury or damage to components does not occur.

For safe handling of pumps and pump units slings should be used. The position of the slings will depend upon the specific pump/unit construction and should be carried out by personnel with the relevant experience to ensure that the pump is not damaged and injury to personnel does not occur.

If eyebolts do exist then these should only be used for lifting the individual components for which they are supplied.

#### 1.3.2 STORAGE

##### SHORT TERM STORAGE

**Where a pump has to be stored for 6 months or less then the following steps are advised:-**

1. Store pump inside wherever possible or if this is not feasible then provide protective covering. Do not allow moisture to collect around the pump.
2. Remove the drain plug, if fitted. Any inspection plates fitted should also be removed to ensure that the suction housing can drain and dry completely.
3. See Manufacturers Instructions for mechanical seal storage procedures.

##### LONG TERM STORAGE

If the pump is to be kept in storage for more than six months then in addition to the above the following procedures should be carried out regularly (every 2 - 3 weeks if possible):

1. If practicable rotate the pump at least three quarters of one revolution to avoid the rotor setting in the stator.
2. Note, however, that the pump is not to be rotated for more than two revolutions each time because damage could be caused to the rotor/ stator elements.



##### IMMEDIATELY PRIOR TO INSTALLATION AND STARTING

**Before installing the pump please ensure that all plugs and inspection plates are replaced.**

#### 1.4 HYDRAULIC DRIVE

When the motor is being connected and checked for rotation, the start/stop sequence must be instantaneous to prevent dry running or pressurising of upstream equipment. (Check direction arrow on pump nameplate). The drive installation should include appropriate isolating equipment to ensure that the pump unit is safe to work on.

# Installation, Operation & Maintenance Instructions

## 1.4.1 ELECTRICAL



Electrical connection should only be made using equipment suitable for both rating and environment. Where any doubts exist regarding the suitability of equipment, Mono Pumps Limited, should be consulted before proceeding. Normally the Mono pump should be installed with starting equipment arranged to give direct on line starting.

Earthing points will be provided on electric drives (if supplied) and it is essential that these are correctly connected. When the motor is being wired and checked for rotation, the start/stop sequence must be instantaneous to prevent dry running or pressurising upstream equipment. (Check direction arrow on pump nameplate). The electrical installation should include appropriate isolating equipment to ensure that the pump unit is safe to work on.

## 1.5 RELIEF VALVES/OVER PRESSURISATION

It is recommended that a suitable safety device is installed on the discharge side of the pump to prevent over-pressurisation of the system.

### IMPORTANT



**The pump must never run against a closed inlet or outlet valve, as this could result in the generation of excessively high pressures and mechanical failure.**

## 1.6 GENERAL SAFETY



**WHERE MONO PUMPS LIMITED HAVE SUPPLIED A BARESHAFT PUMP THE ONUS IS ON THE USER TO FIT ADEQUATE GUARDS IN COMPLIANCE WITH THE REQUIREMENTS OF THE RELEVANT REGULATIONS.**

All nuts and bolts, securing flanges and base mounting fixtures must be checked for tightness before operation. All guards must be securely fixed in position. When commissioning the plant, all joints in the system must be checked thoroughly for leakage.

If, when starting, the pump does not appear to operate correctly, the plant must be shut down immediately and the cause of the malfunction established before operations are recommenced.

It is recommended that depending upon plant system operation, either a combined vacuum and pressure gauge, or a vacuum gauge only be fitted to the pump inlet port, and a pressure gauge fitted to the outlet port, these will then continuously monitor the pump operating conditions. May contain substances from the ECHA SVHC Candidates List (REACH - Regulation (EC) No. 1907/2006)

## 1.7 DUTY CONDITIONS

Pumps should only be installed on duties for which Mono Pumps Limited have specified the materials of construction, flow rates, pressure, temperature, speed etc. Where dangerous materials are to be pumped, consideration must be given to the safe discharge from relief valves, gland drains etc.



**If the duty should be changed Mono Pumps Ltd should be contacted and their recommendations sought in the interest of application, safety of plant, efficiency and pump life.**

## 2. START-UP PROCEDURE

Pumps must be filled with liquid before starting. The initial filling is not for priming purposes, but to provide the necessary lubrication of the stator until the pump primes itself. When the pump is stopped, sufficient liquid will normally be trapped in the rotor/stator assembly to provide lubrication upon re-starting.

If, however, the pump has been left standing for an appreciable time, moved to a new location, or has been dismantled and re-assembled, it must be refilled with liquid and given a few turns before starting.

The pump is normally somewhat stiff to turn by hand owing to the close rotor/stator fit. However, this stiffness disappears when the pump is running normally against pressure.

### 2.1 DRY RUNNING



**NEVER RUN THE PUMP IN A DRY CONDITION EVEN FOR A FEW REVOLUTIONS OR THE STATOR WILL BE DAMAGED IMMEDIATELY. CONTINUAL DRY RUNNING COULD PRODUCE SOME HARMFUL OR DAMAGING EFFECTS.**



# Installation, Operation & Maintenance Instructions

## 2.2 PUMP ROTATION DETAILS

The normal direction of rotation is anti-clockwise when viewed from the drive end (suction on gland), but the pump may be run clockwise for cleaning and maintenance purposes, taking 2.1 into account at all times.



**Maximum pressure rating for suction housing and gland is 1 bar (15 psi) unless otherwise stated by Mono Pumps Ltd.**

## DIRECTIONS OF ROTATION



**BEFORE THE DIRECTION OF ROTATION IS CHANGED, MONO PUMPS LIMITED MUST BE CONSULTED SO THAT THE SUITABILITY OF THE PUMP CAN BE CONFIRMED WHEN OPERATING ON THE NEW DUTY.**

### 2.3.1. LIPSEAL GLAND

Lipseals are supplied as a pair fitted in a 'back to back' arrangement as standard. **NOTE**, pressure limits as 2.2.

### 2.3.2 MECHANICAL SEALS

When a mechanical seal is fitted to the pump it may be necessary to provide a barrier fluid to some part of the seal. This should be provided in line with the seal manufacturers instructions.

## 2.4. GUARDS



In the interests of safety, and in accordance with all relevant Health and Safety regulations, all guards must be replaced after necessary adjustments have been made to the pump.

## 2.5 WARNING/CONTROL DEVICE

Prior to operating the pump, if any warning or control devices are fitted these must be set in accordance with their specific instructions.

## 2.6 PUMP OPERATING TEMPERATURE

The range of temperatures the pump surfaces will develop is dependent upon factors such as product temperature and ambient temperature of the installation. There may be instances where the external pump surface can exceed 50°C.

In these instances, personnel must be made aware of this and suitable warnings/guarding used.

## 2.7 NOISE LEVELS

1. The sound pressure level should not exceed 85dB at one metre distance from the pump.
2. This is based on a typical installation and does not necessarily include noise from other sources or any contribution from building reverberation or installation pipework
3. It is recommended the actual pump unit noise levels are ascertained once the unit is installed and running at duty conditions

## 2.8 LUBRICATION

Pumps should be inspected periodically to see if grease replenishment is necessary, and if so, grease should be added until the chambers at the ends of the bearing spacer are approximately one third full.

Periodic bearing inspection is necessary to maintain optimum bearing performance. The most expedient time to inspect is during periods of regular scheduled equipment downtime - for routine maintenance or for any other reason.

Under tropical or other arduous conditions, however, a more frequent examination may be necessary. It is therefore advisable to establish a correct maintenance schedule or periodic inspection.

BP Energrease LC2 or its equivalent must be used for replenishment.

## 2.9 PUMP UNITS

Where a pump unit is dismantled and re-assembled, consideration must be given to ensure that where appropriate the correct alignment of pump and drive is maintained.

## 2.10 CLEANING PRIOR TO OPERATION

During the commissioning of a new pump or recommissioning of an overhauled pump, it is advisable to clean the pump prior to the initial operation of the pump in the process.

## 2.11 EXPLOSIVE PRODUCTS/HAZARDOUS ATMOSPHERES

In certain instances the product being pumped may well be of a hazardous nature.

In these installations consideration must be given to provide suitable protection and appropriate warnings to safeguard personnel and plant.



# Installation, Operation & Maintenance Instructions

## 2.12 ACCESS PORTS



Where access ports are fitted then the following steps must be followed prior to removal:



1. Pump must be shut down and power supply isolated.
2. Protective clothing should be worn, especially if the pumped product is obnoxious/hazardous to health.
3. Remove access plate with care utilising where possible drip trays to collect product leakage.

Access ports are included to assist in removing blockages and to allow a visual check on the components within the suction chamber and aid dismantling.

Re-assembly of the plate should be completed using new gaskets prior to the pump being started.

## 2.13 MAINTENANCE OF WEARING COMPONENTS

### 2.13.1 ROTOR AND STATOR

The wear rate on these components is dependent on many factors, such as product abrasivity, speed, pressure etc.

When pump performance has reduced to an unacceptable level one or possibly both items will need replacing.

### 2.13.2 SHAFT – LIPSEAL GLAND

The wear rate of the gland area is dependent on many factors such as product abrasivity and speed.

Regular gland maintenance will maximise the life of the shaft.

Replacement of both seals and shaft will be necessary when shaft sealing becomes difficult to achieve.

### 2.13.3 FLEXISHAFT DRIVE

With this design there are no wearing items to replace in the drive train, however, if during routine inspection the shaft is visibly damaged / distorted or the protective coating is damaged, then this item should be replaced to avoid unexpected breakdowns. This component is integral with the rotor throughout this pump range and can only be replaced as an assembly.

## 3.0 ASSEMBLY AND DISMANTLING

Section 4 contains the steps to dismantle and re-assemble the pump. All fastenings must be tightened securely and when identified the appropriate torque figures should be used.

### 3.1 USE OF ITEMS NOT APPROVED OR MANUFACTURED BY MONO PUMPS LIMITED

The pump and its components have been designed to ensure that the pump will operate safely within the operational guidelines.

The use of replacement items that are not approved by or manufactured by Mono Pumps Limited may affect the safe operation of the pump and it may therefore become a safety hazard to both operators and other equipment.

In these instances the declaration provided will therefore become invalid. The guarantee referenced in the terms and conditions of sale will also be invalidated if replacement items are not approved or manufactured by Mono Pumps Ltd.

### DISPOSAL OF WORN COMPONENTS



*When replacing wearing parts, please ensure disposal of used parts is carried out in compliance with local environmental legislation. Particular care should be taken when disposing of lubricants.*

# Installation, Operation & Maintenance Instructions

## 3.2 RECOMMENDED LIFTING POINTS

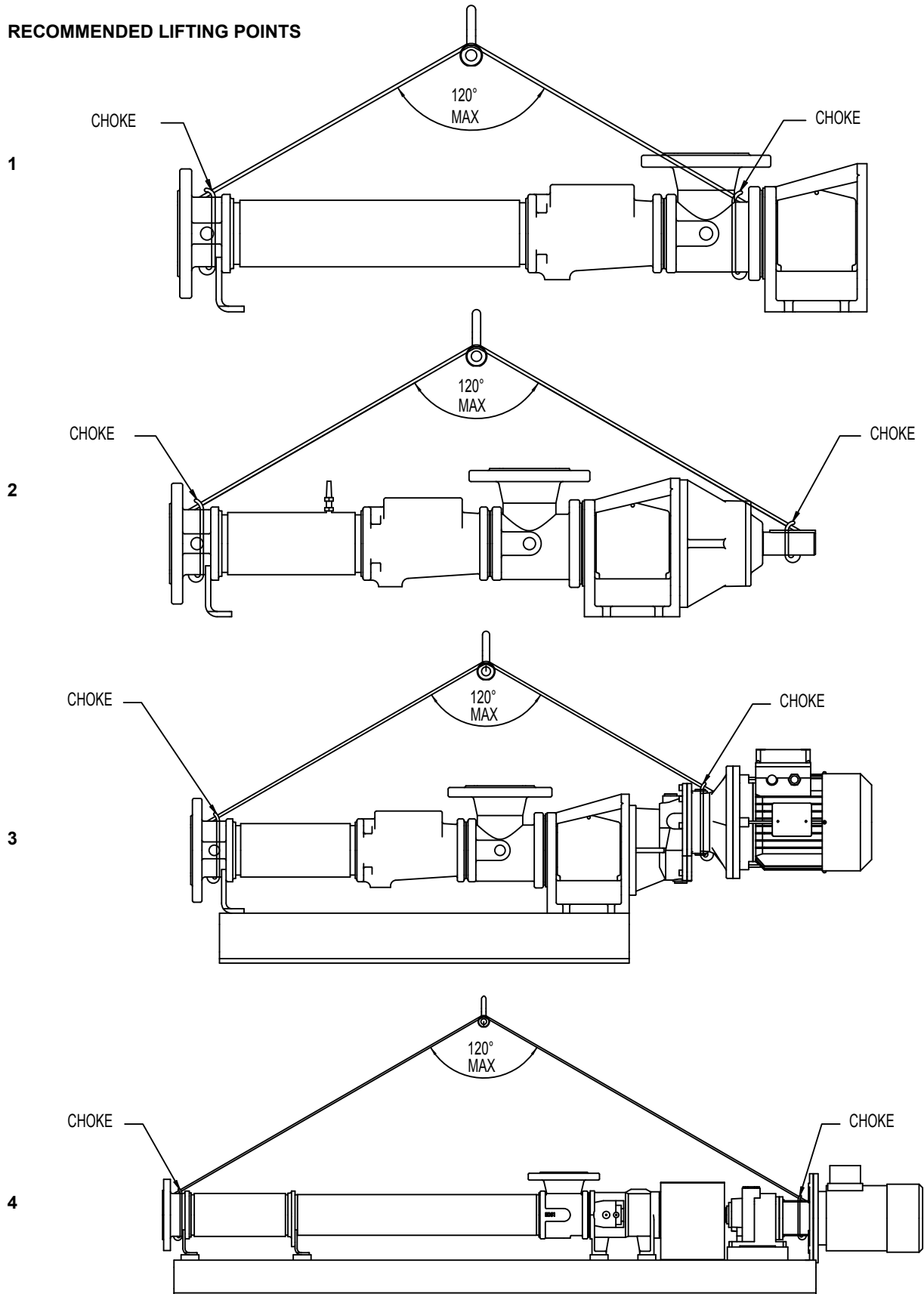

# Installation, Operation & Maintenance Instructions

## 3.3 PUMP AND WEAR PARTS WEIGHTS.

**NOTE:** Weights are for guidance purpose only. Please refer to the documentation issued with your pump or spares.

### X Range

Model	Weight (kg)			
	Pump	Stator	Rotor Flexi Assembly	Shaft
X043	75	11	9	1.7
X054	140	24	21	2.9
X062	125	17	12	2.9
X063	155	34	30	2.9
X071	130	17	16	2.9
X072	230	42	30	2.7
X073	245	62	42	2.7
X074	275	83	56	4.2
X091	225	40	29	2.7
X093	360	74	80	4.2

# Diagnostic Chart

SYMPTOMS	POSSIBLE CAUSES
1. NO DISCHARGE 2. LOSS OF CAPACITY 3. IRREGULAR DISCHARGE 4. PRIMING LOST AFTER START 5. PUMP STALLS AT START UP 6. PUMP OVERHEATS 7. MOTOR OVERHEATS 8. EXCESSIVE POWER ABSORBED BY PUMP 9. NOISE AND VIBRATION 10. PUMP ELEMENT WEAR 11. EXCESSIVE GLAND OR SEAL WEAR 12. GLAND LEAKAGE 13. SEIZURE	1. 2. 3. 7. 26. 28. 29. 3. 4. 5. 6. 7. 8. 9. 10. 22. 13. 16. 17. 21. 22. 23. 29 3. 4. 5. 6. 7. 8. 13. 15. 29. 3. 4. 5. 6. 7. 8. 13. 15 8. 11. 24. 8. 9. 11. 12. 18. 20 8. 11. 12. 15. 18. 20. 8. 11. 12. 15. 18. 20 3. 4. 5. 6. 7. 8. 9. 11. 13. 15. 18. 19. 20. 22. 23. 27. 31 9. 11. 12. 14. 25. 30. 13. 14. 9. 11. 12. 20.
LIST OF CAUSES	REMEDIAL ACTIONS
1. INCORRECT DIRECTION OF ROTATION 2. PUMP UNPRIMED 3. INSUFFICIENT N.P.S.H. AVAILABLE 4. PRODUCT VAPORISING IN SUPPLY LINE 5. AIR ENTERING SUPPLY LINE 6. INSUFFICIENT HEAD ABOVE SUPPLY VESSEL OUTLET 7. FOOTVALVE/STRAINER OBSTRUCTED OR BLOCKED 8. PRODUCT VISCOSITY ABOVE RATED FIGURE 9. PRODUCT TEMP. ABOVE RATED FIGURE 10. PRODUCT VISCOSITY BELOW RATED FIGURE 11. DELIVERY PRESSURE ABOVE RATED FIGURE 12. GLAND OVERTIGHT 13. GLAND UNDERTIGHT 14. GLAND FLUSHING INADEQUATE 15. PUMP SPEED ABOVE RATED FIGURE 16. PUMP SPEED BELOW RATED FIGURE 17. BELT DRIVE SLIPPING 18. COUPLING MISALIGNED 19. INSECURE PUMP/DRIVE MOUNTING 20. SHAFT BEARING WEAR/FAILURE 21. WORN PUMP ELEMENT 22. RELIEF VALVE CHATTER 23. R.V. INCORRECTLY SET 24. LOW VOLTAGE 25. PRODUCT ENTERING PACKING AREA 26. DRIVE TRAIN BREAKAGE 27. NEGATIVE OR VERY LOW DELIVERY HEAD 28. DISCHARGE BLOCKED/VALVE CLOSED 29. STATOR TURNING 30. STUFFING BOX "EATS" PACKING 31. VEE BELTS	1. REVERSE MOTOR 2. BLEED SYSTEM OF AIR/GAS 3. INCREASE SUCTION HEAD OR REDUCE SPEED/TEMP. 4. INCREASE N.P.S.H. AVAILABLE (SEE 3 ABOVE) 5. CHECK PIPE JOINTS/GLAND ADJUSTMENT 6. RAISE VESSEL/INCREASE PIPE SIZE 7. CLEAN OUT SUCTION LINE/VALVES 8. DECREASE PUMP SPEED/INCREASE TEMP. 9. COOL THE PRODUCT 10. INCREASE PUMP SPEED/REDUCE TEMP. 11. CHECK FOR BLOCKAGES IN DELIVERY LINE 12. ADJUST GLAND SEE O&M INSTRUCTIONS 13. ADJUST GLAND SEE O&M INSTRUCTIONS 14. CHECK FLUID FLOWS FREELY INTO GLAND 15. DECREASE PUMP SPEED 16. INCREASE PUMP SPEED 17. RE-TENSION BELTS 18. CHECK AND ADJUST ALIGNMENT 19. CHECK AND TIGHTEN ALL PUMP MOUNTINGS 20. REPLACE BEARINGS 21. FIT NEW PARTS 22. CHECK CONDITION OF VALVE/RENEW 23. RE-ADJUST SPRING COMPRESSION 24. CHECK VOLTAGE/WIRING SIZES 25. CHECK PACKING CONDITION AND TYPE 26. CHECK AND REPLACE BROKEN COMPONENTS 27. CLOSE DELIVERY VALVE SLIGHTLY 28. REVERSE PUMP/RELIEVE PRESSURE/CLEAR BLOCKAGES 29. REPLACE WORN PARTS/TIGHTEN UP STATOR BOLTS 30. CHECK FOR WORN SHAFT AND REPLACE 31. CHECK AND ADJUST TENSION OR REPLACE

# Drawing Reference Numbers

<u>DRG.</u> <u>REF</u>	<u>DESCRIPTION</u>	<u>DRG.</u> <u>REF</u>	<u>DESCRIPTION</u>
01A	BODY	P101	BEARING
06A	NAMEPLATE (SOG)	P102	BEARING
06B	NAMEPLATE (DOG)	P103	LIP SEAL
10A	LIPSEALS	P105	HEX. HD. BOLT
11A	BEARING COVER	P106	HEX. NUT
15A	THROWER GUARD	P107	WASHER
20B	GASKET (SUCTION CHAMBER)	P108	SPRING WASHER
22A	STATOR	P109	THRD. CUT SCREW
23A	SUCTION CHAMBER	P110	WASHER
24A	END COVER	P111	SOC. HD CAP SCREW
25A	ROTOR/FLEXISHAFT ASSY	P112	SPRING WASHER
32A	SHAFT	P113	DRIVESCREW
35A	BEARING SPACER	P401	SQ PAR KEY
47A	HALF RING	P402	SEAL
47B	HALF RING	P404	SOC. CAP SCREW
62A	SUPPORT FOOT	P408	LOCKNUT
62B	SUPPORT FOOT	P409	LOCKWASHER
65A	GLAND SECTION	P416	SPRING WASHER
76A	ADAPTOR FLANGE – HALF RINGS	P502	TAPER PLUG
76B	ADAPTOR FLANGE – HALF RINGS	P503	HEX NUT
		P504	SPRING WASHER
		P505	WASHER
		P506	HEX NUT
		P507	SPRING WASHER
		P508	WASHER
		P527	HEX HD BOLT
		P528	SPRING WASHER
		P529	WASHER
		P530	HEX NUT
		P580	HEX HD BOLT
		P581	STUD
		P582	STUD

## IMPORTANT NOTE

THE DRAWING REFERENCES SHOWN GIVE THE DESCRIPTION OF ALL THE PARTS DETAILED ON THE SECTIONAL DRAWINGS IN THIS SECTION OF THE BOOK. THEREFORE SOME OF THE REFERENCES MAY NOT BE SHOWN ON ANY ONE.

# Dismantling & Assembly Diagrams

**X043 ONLY**

**NOTE:-  
ASSEMBLY IS REVERSE OF THIS PROCEDURE TAKING INTO ACCOUNT FASTENER  
TIGHTENING TORQUES, THREAD LOCKING AND FLANGE SEALING AS INDICATED**

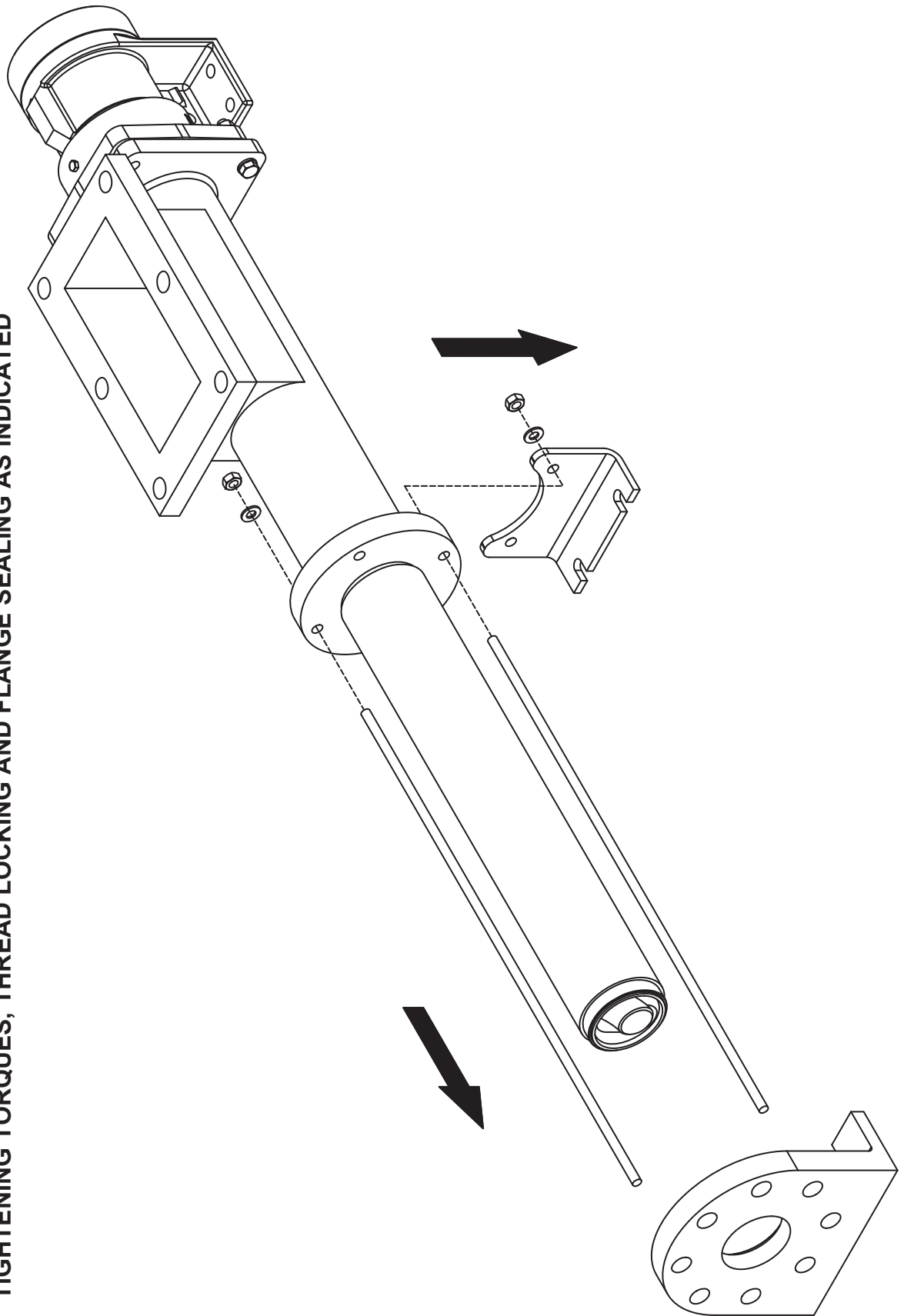

# Dismantling & Assembly Diagrams

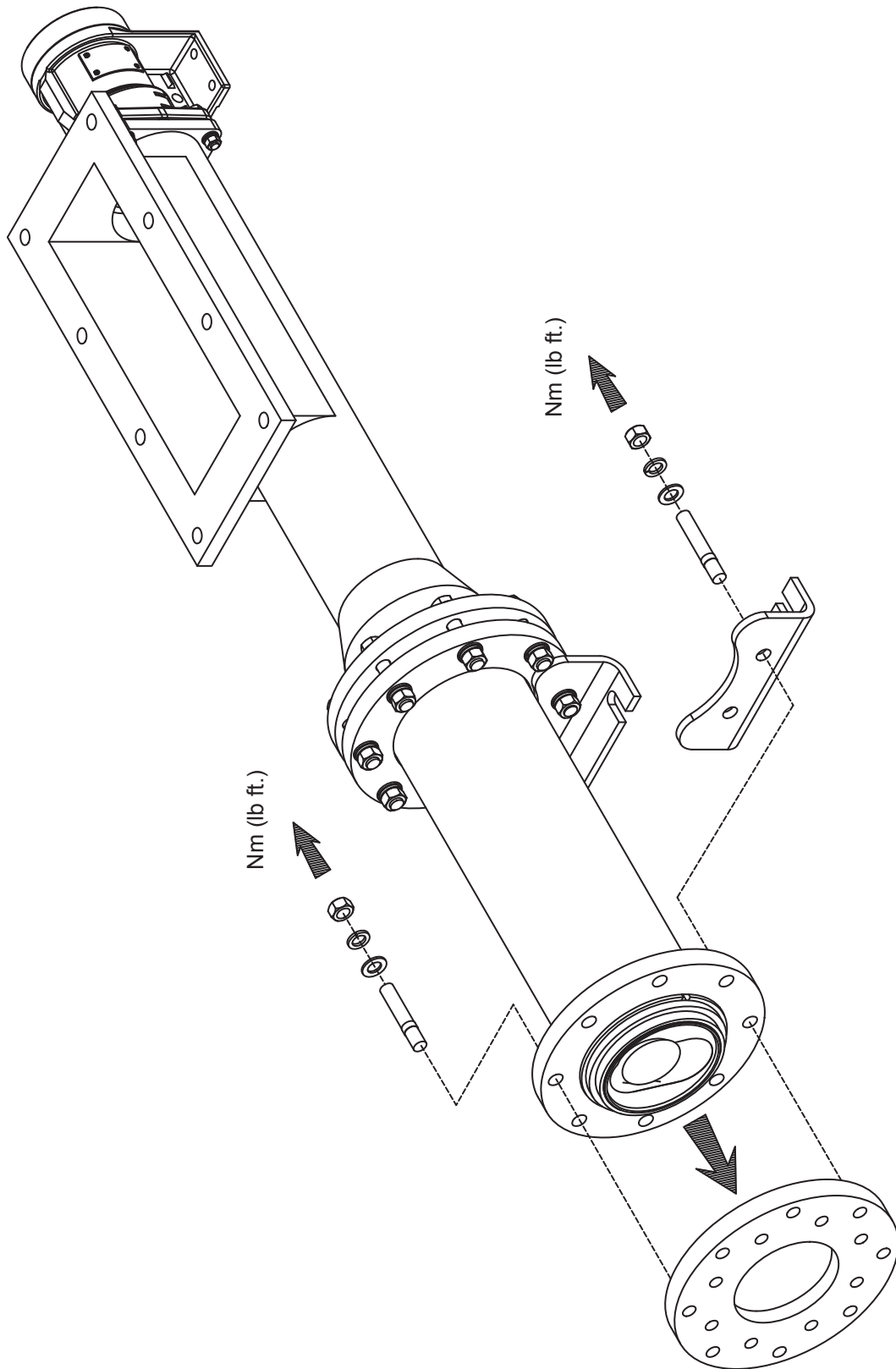

ALL EXCEPT X043



# Dismantling & Assembly Diagrams

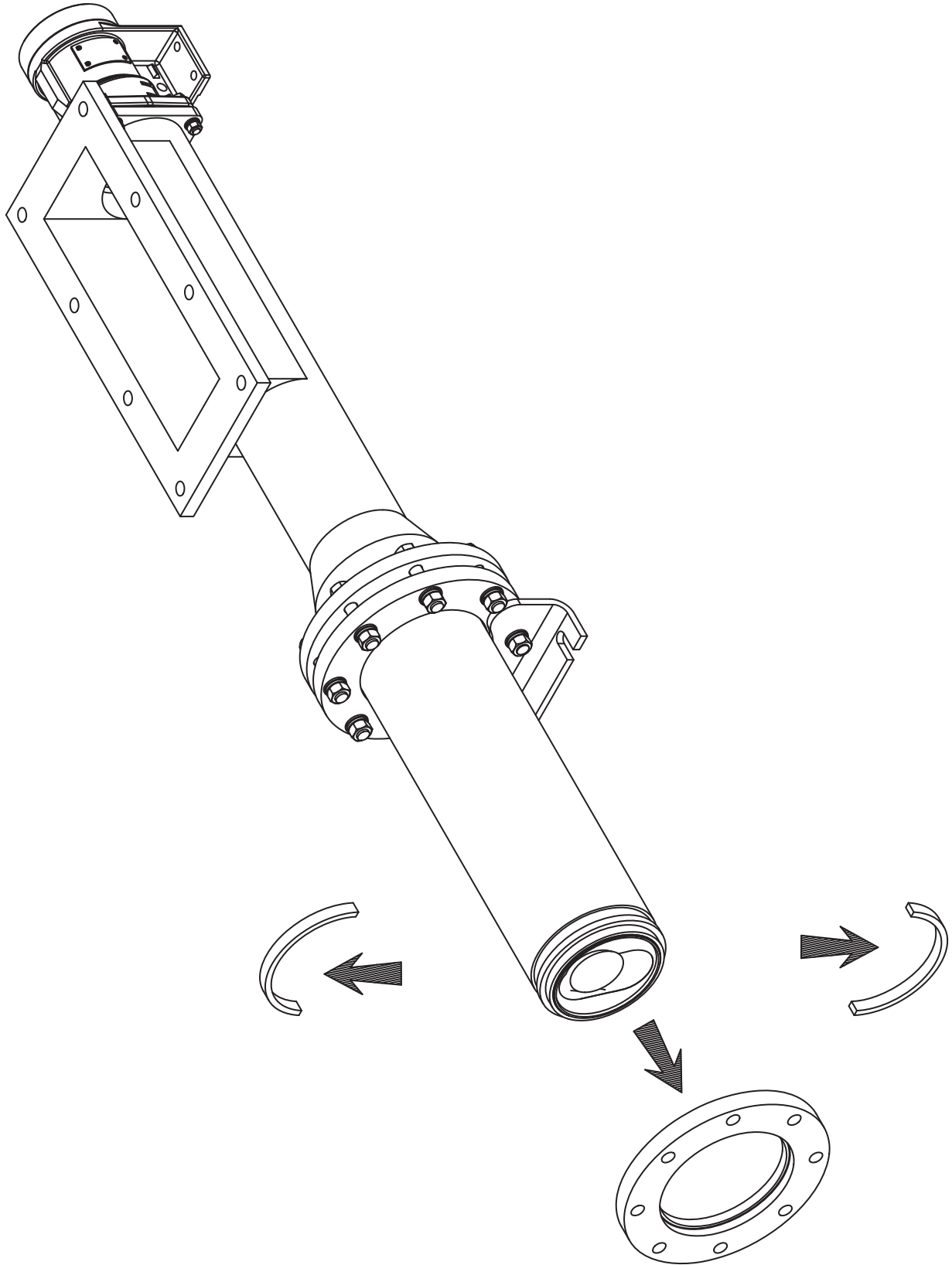

ALL EXCEPT X043

# Dismantling & Assembly Diagrams

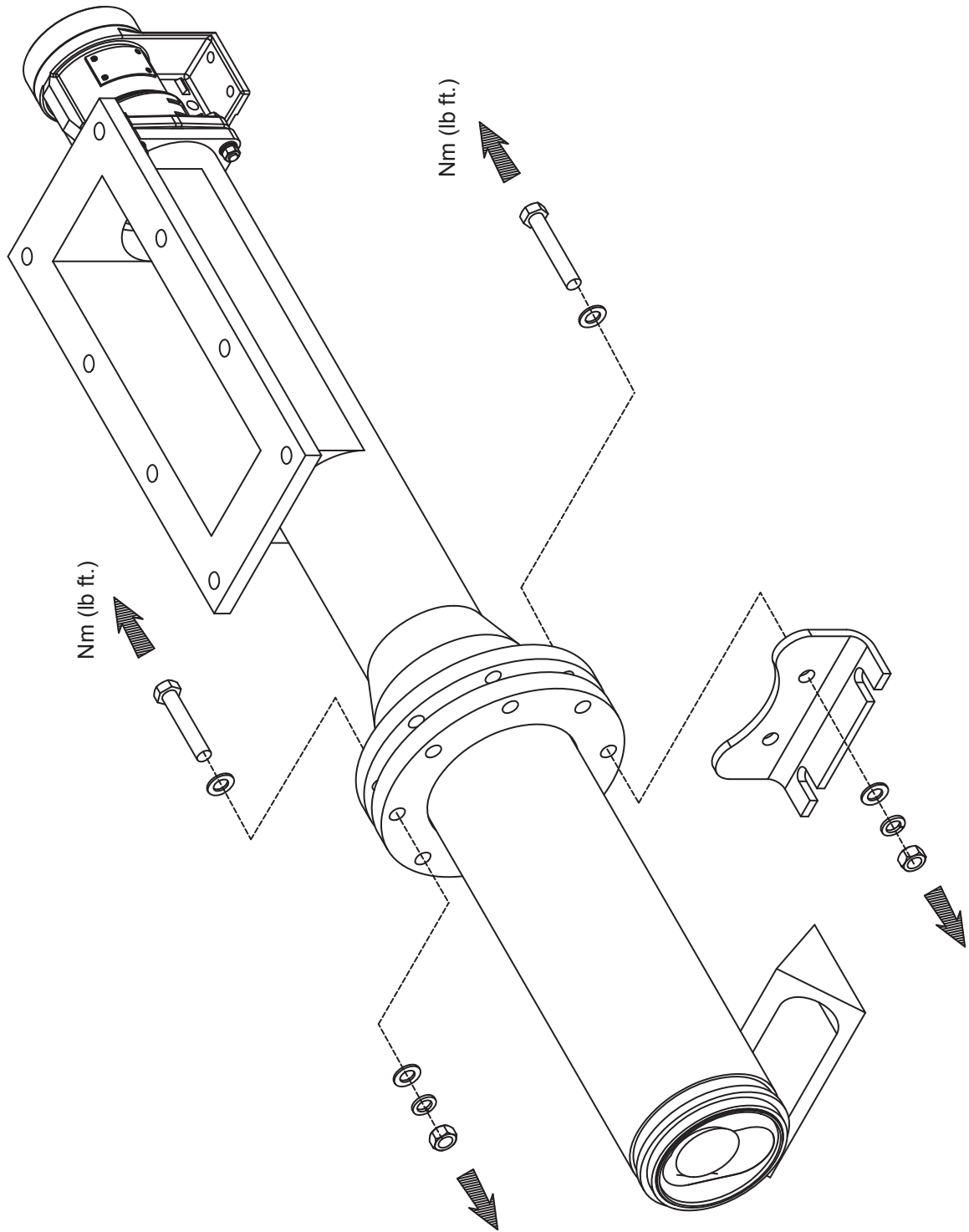

ALL MODELS

# Dismantling & Assembly Diagrams

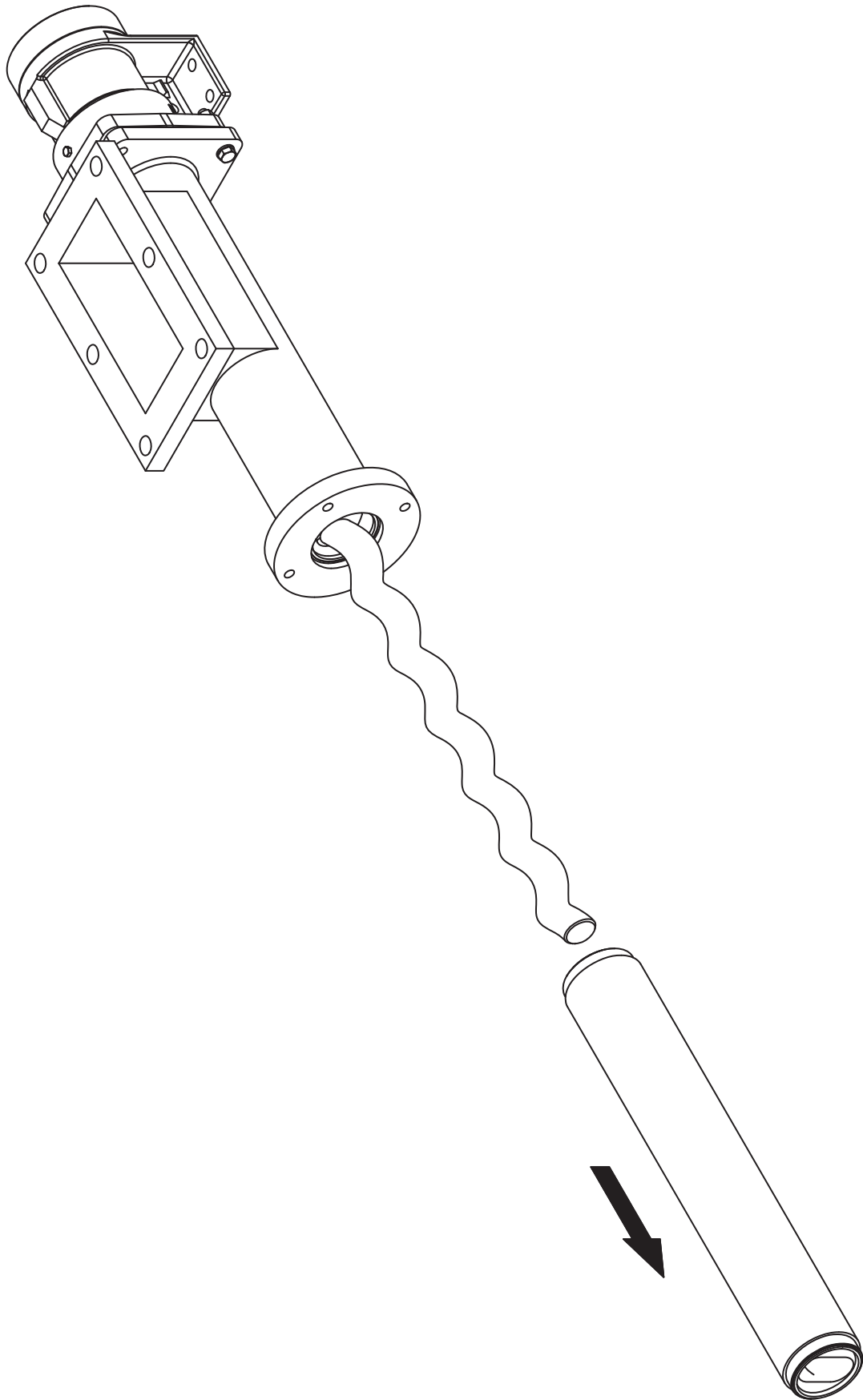

X043 ONLY

# Dismantling & Assembly Diagrams

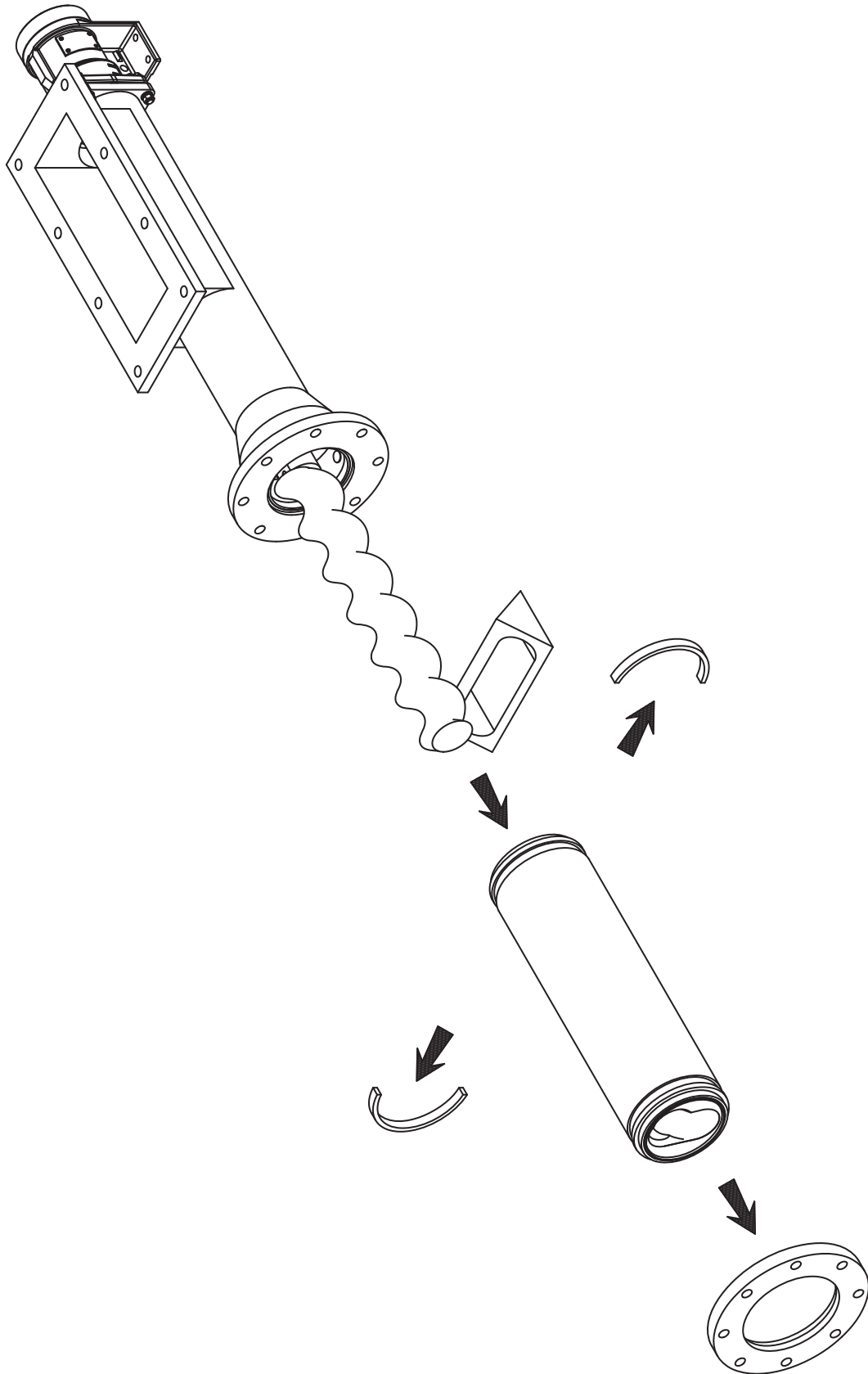

ALL EXCEPT X043

# Dismantling & Assembly Diagrams

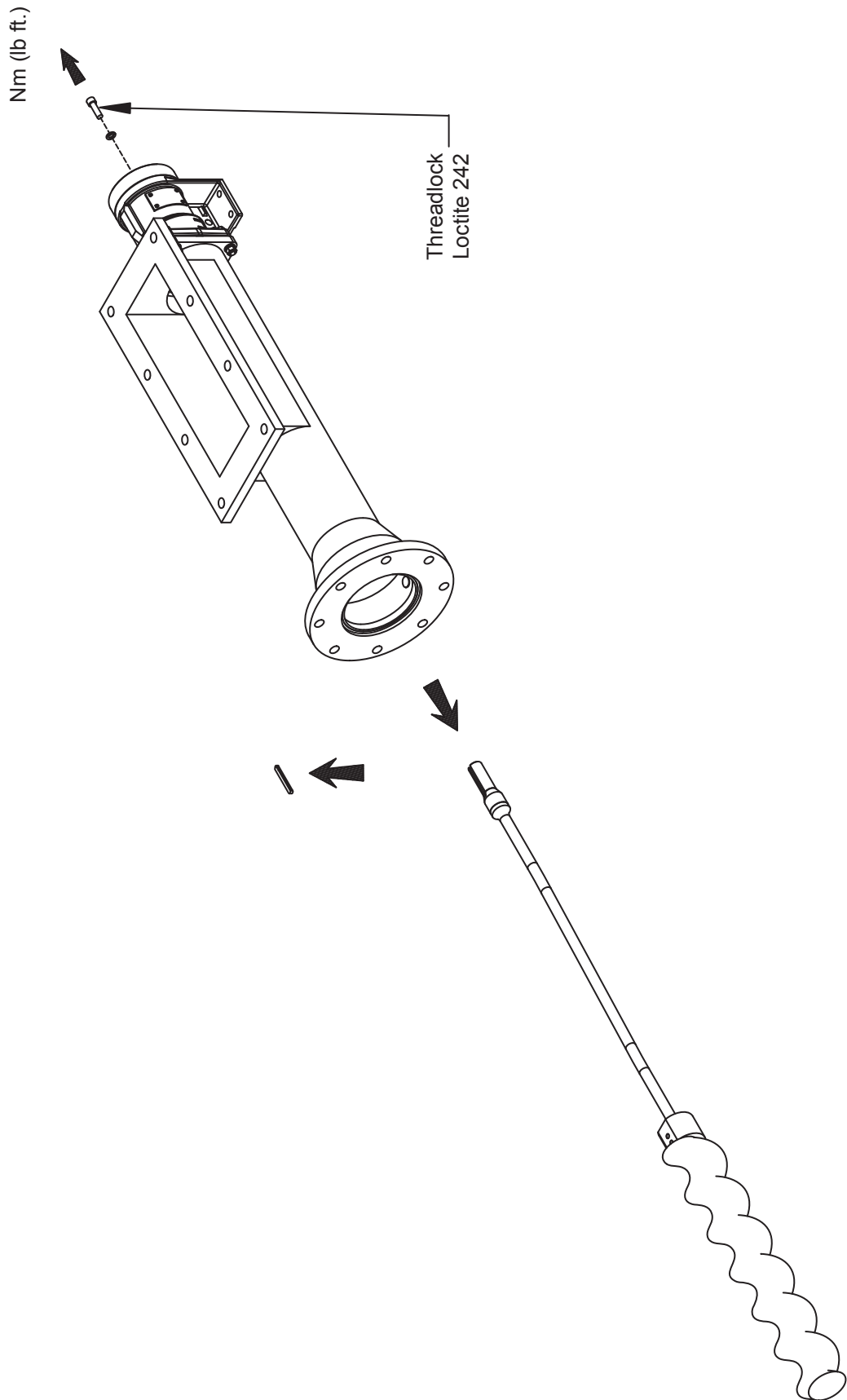

ALL MODELS

# Dismantling & Assembly Diagrams

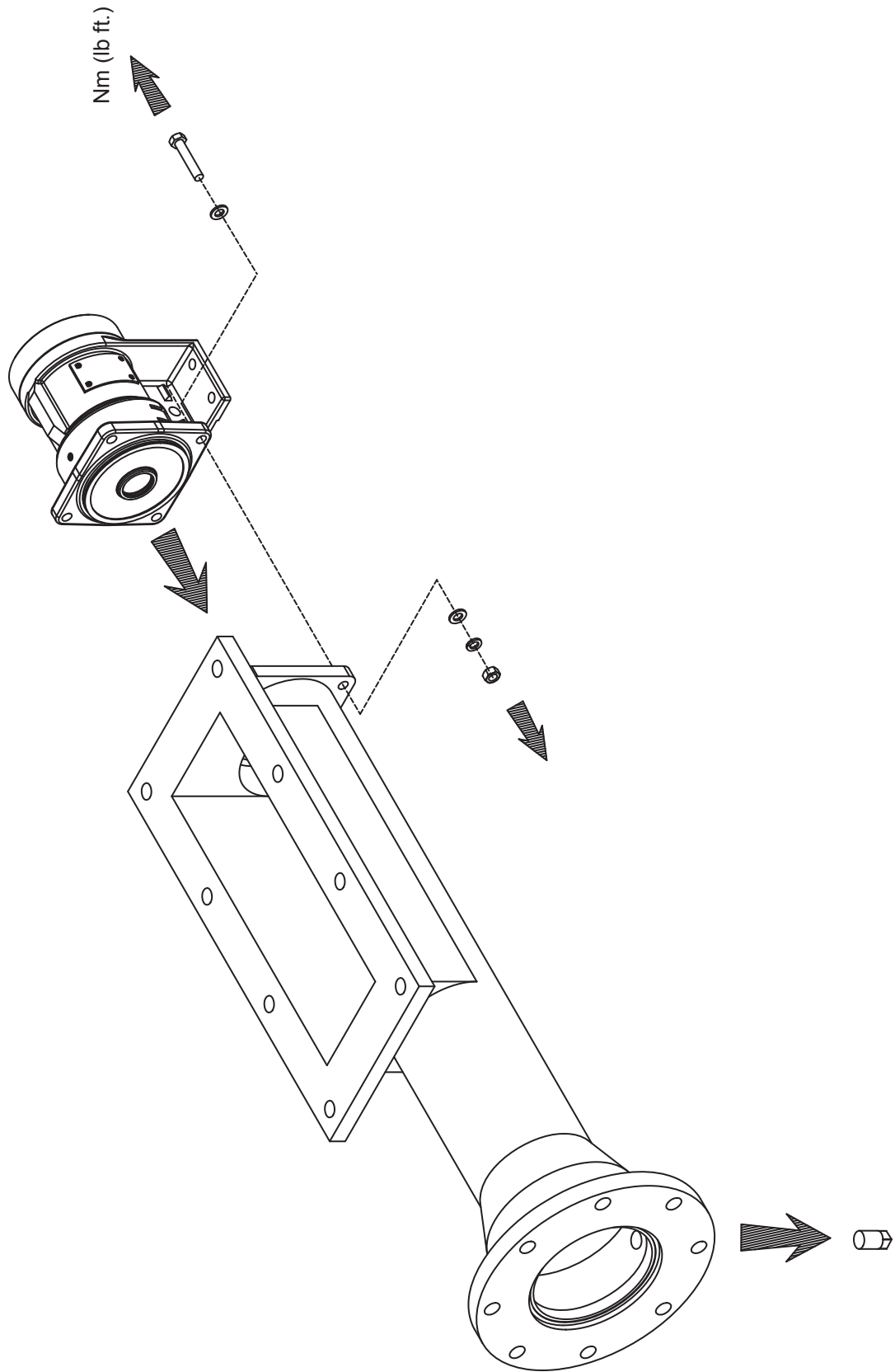

ALL MODELS

# Dismantling & Assembly Diagrams

ALL MODELS

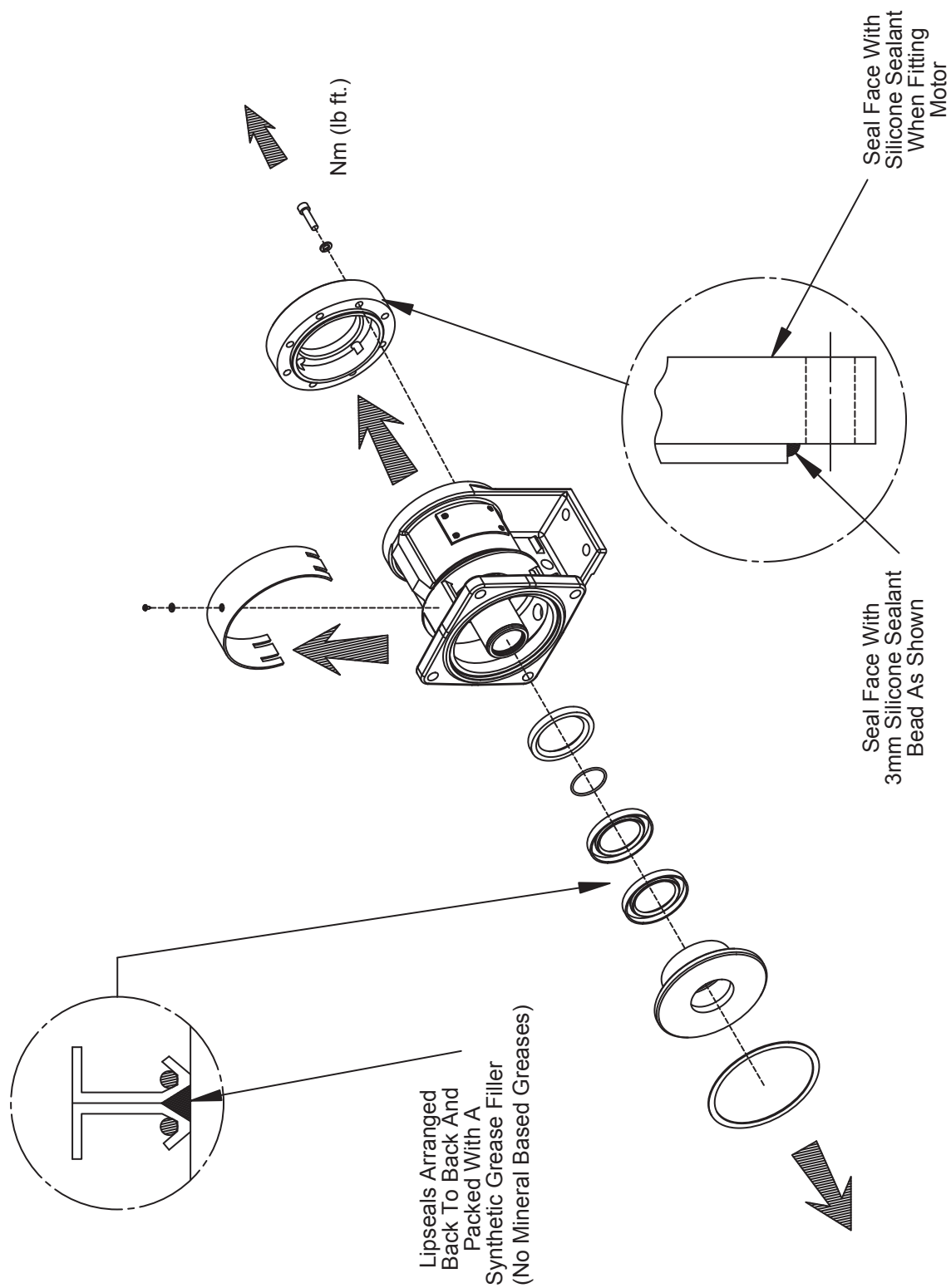



# Dismantling & Assembly Diagrams

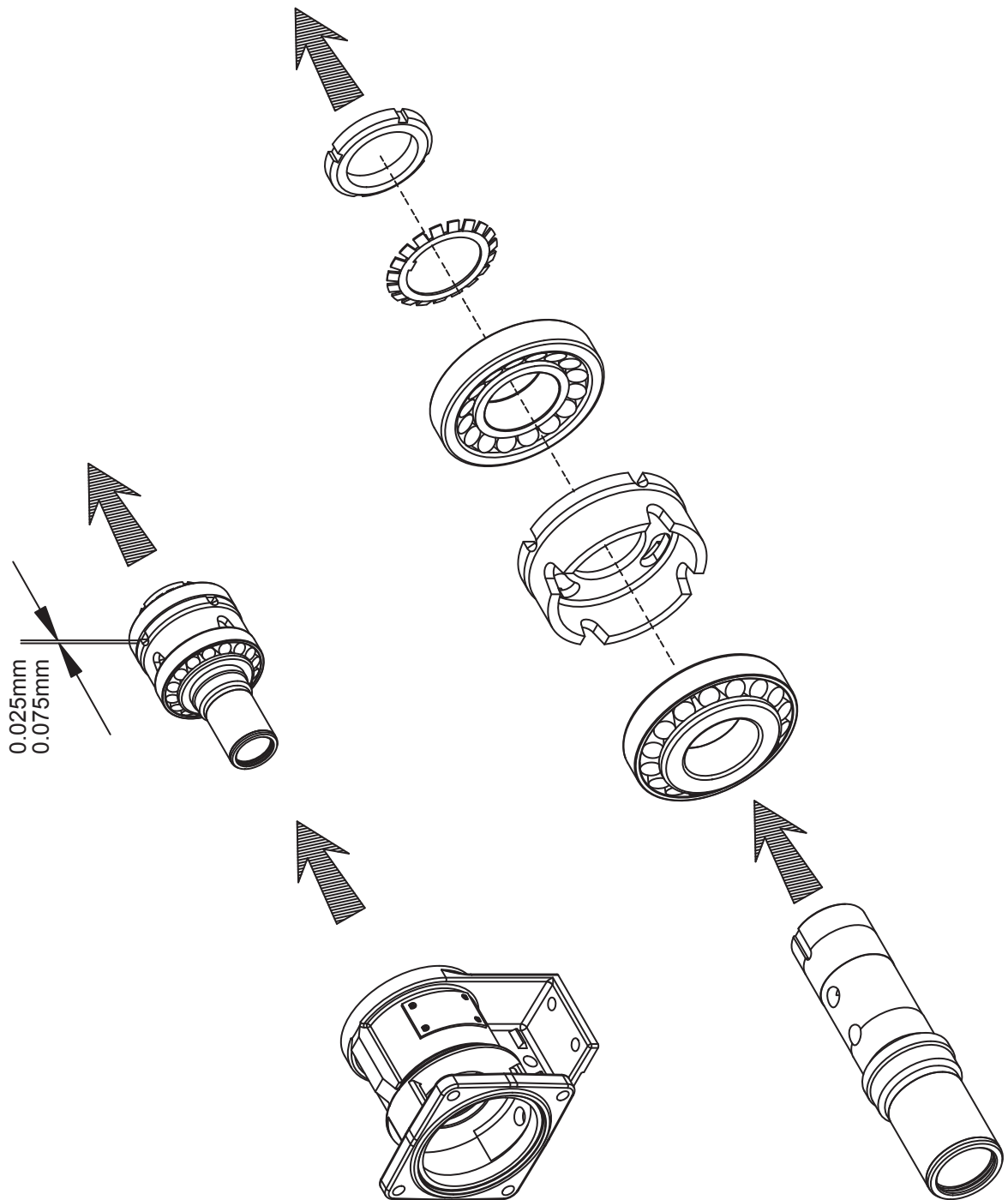

ALL MODELS

# Exploded Views

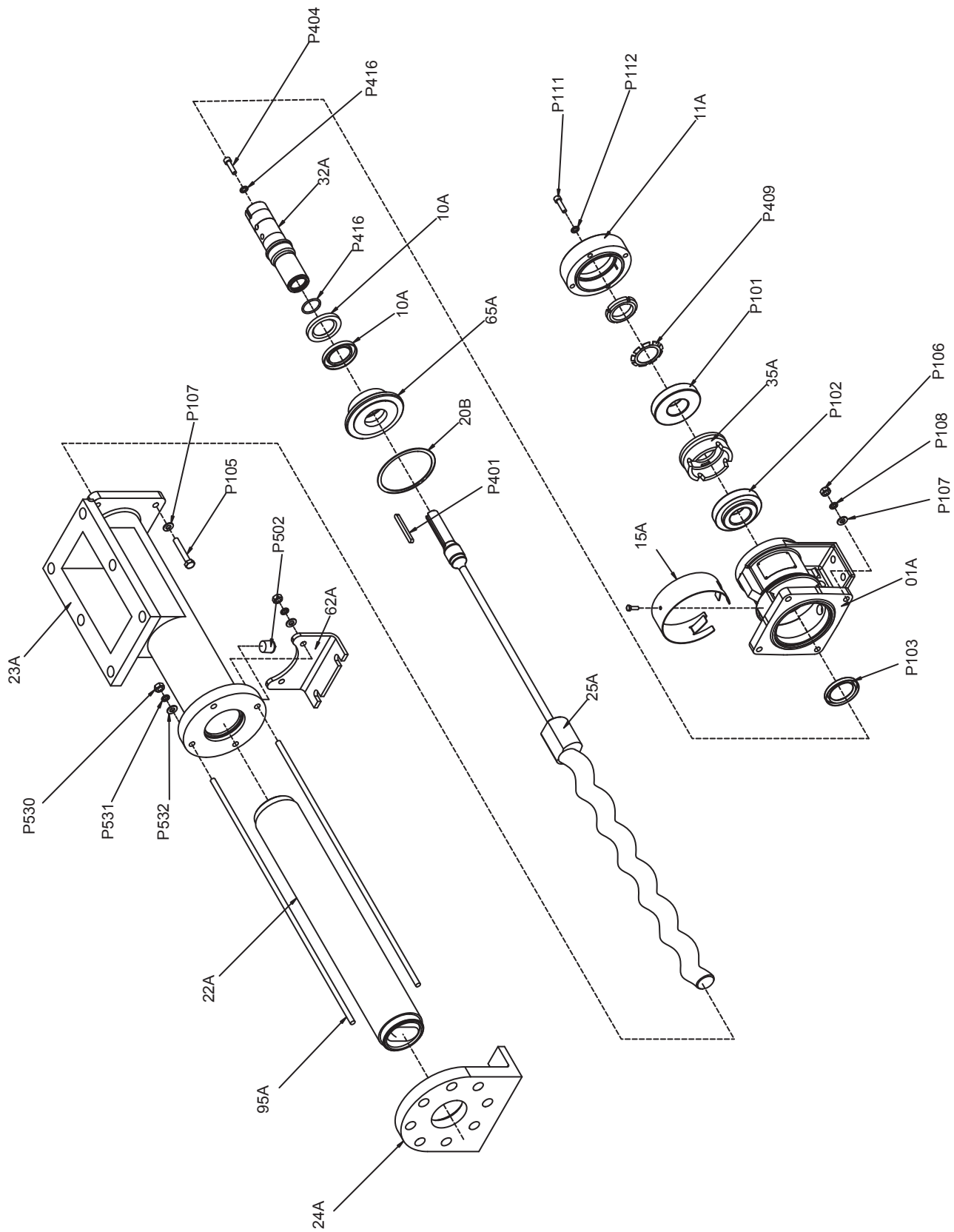

**X043 ONLY**

# Exploded Views

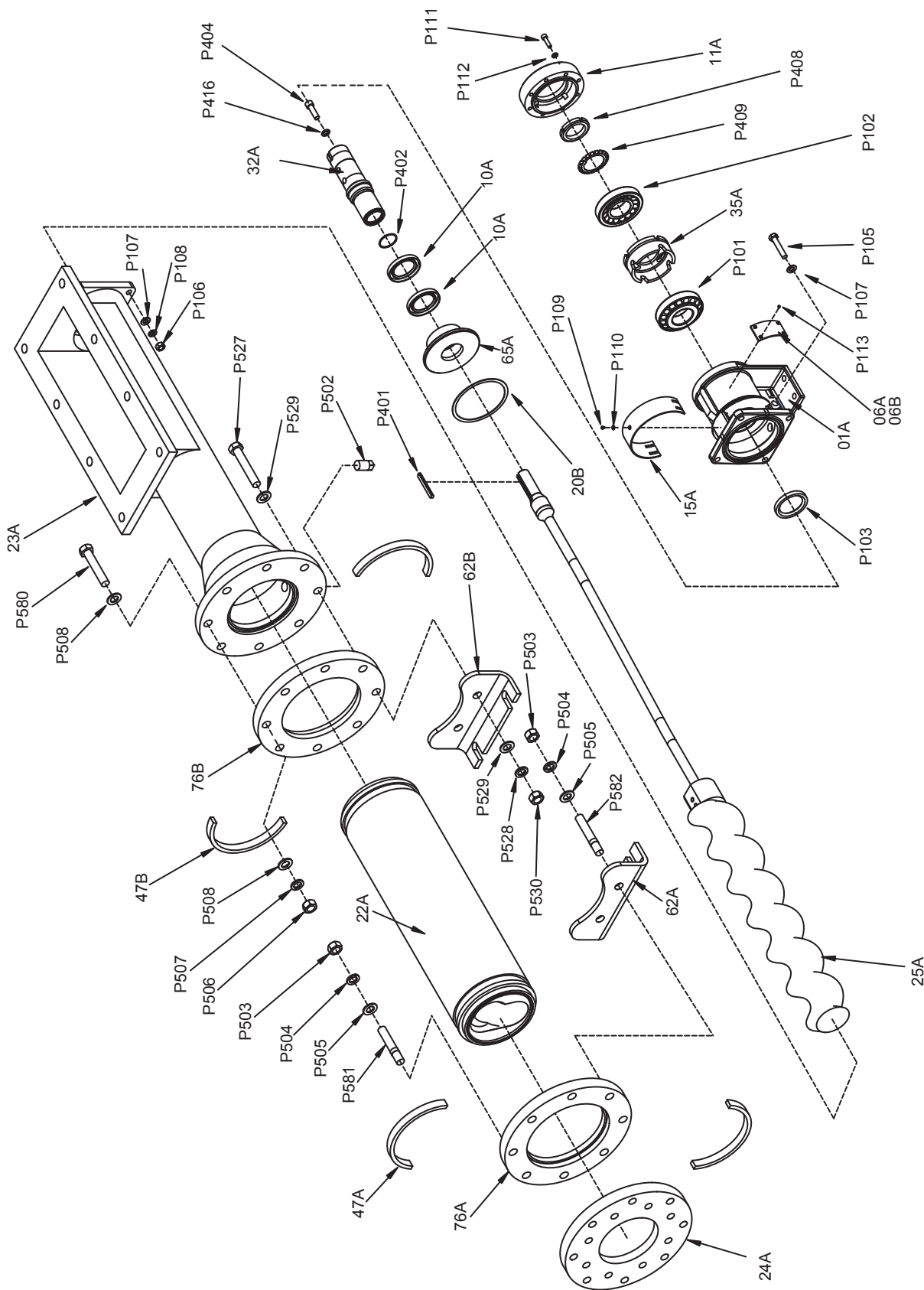

**ALL EXCEPT X043**

# Exploded Views

## X073 LONG COUPLED - DRIVE END

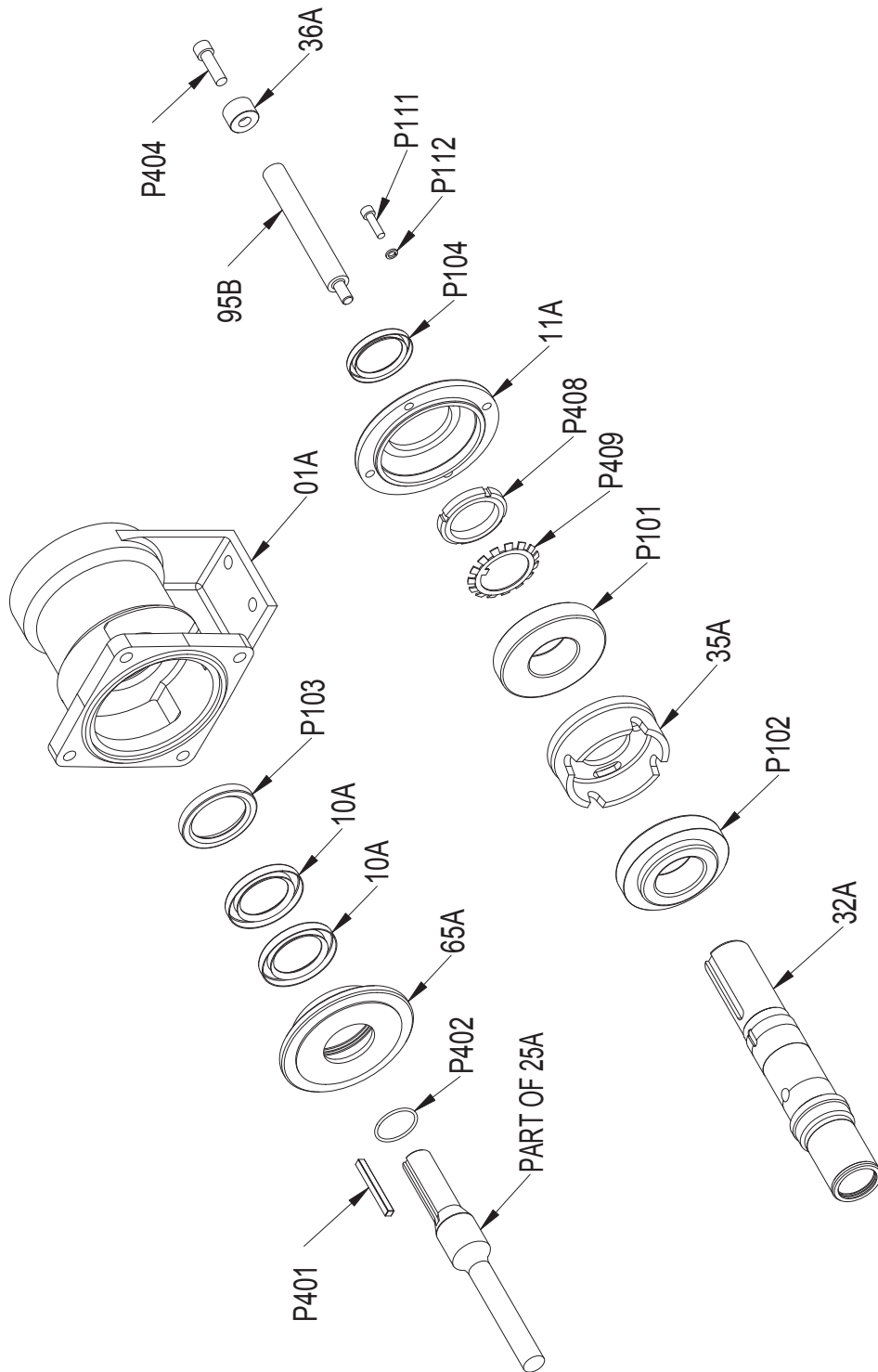

# Exploded Views

## X073 LONG COUPLED - DRIVE END SECTIONAL

Please ensure correct orientation of all lipseals

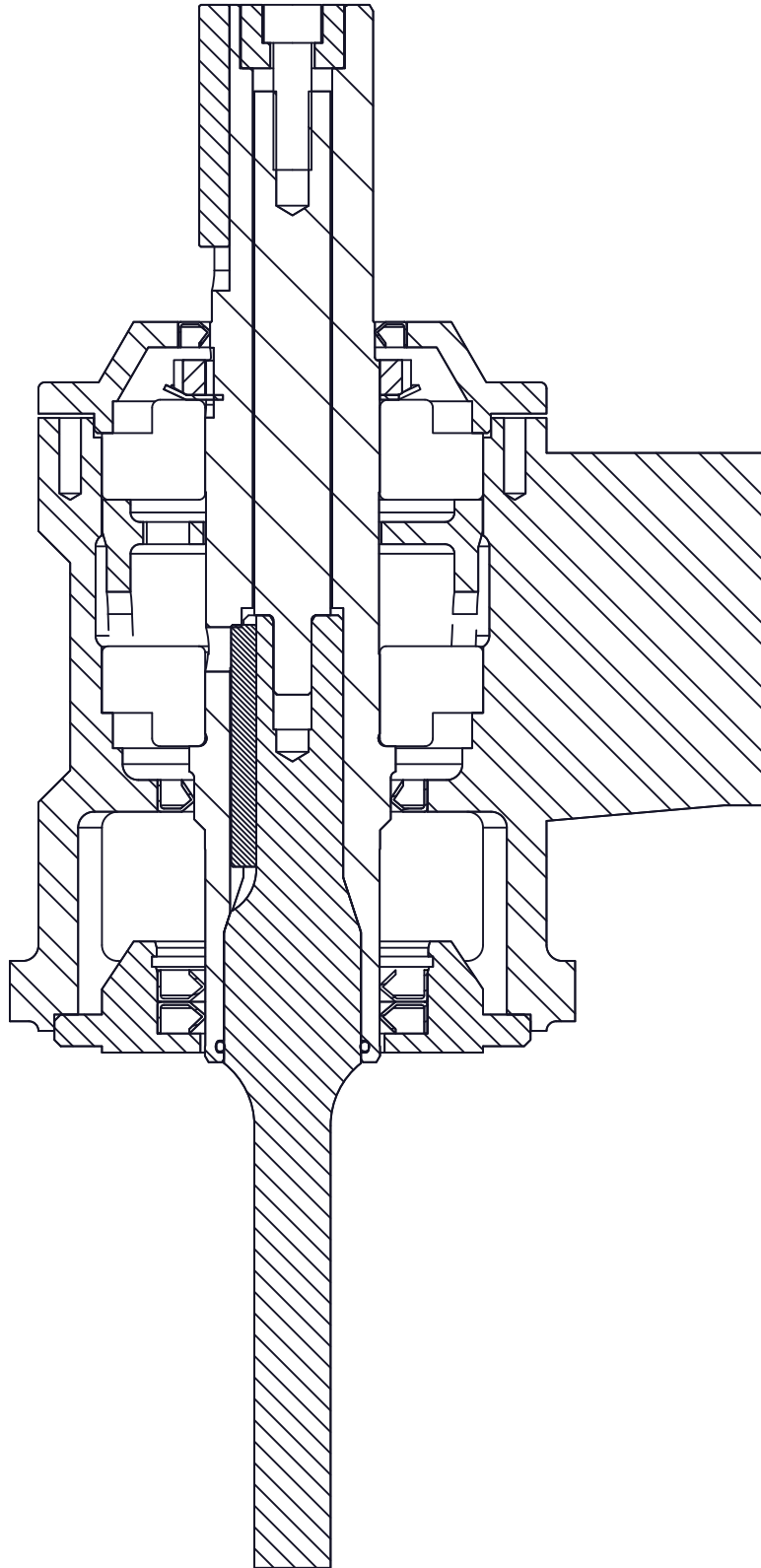

# Torque Tightening Figures

PUMP SIZE	SUCTION CHAMBER/BODY	BEARING COVER	FLEXISHAFT TIE BOLT	STATOR TIE RODS
	Nm (lb ft)	Nm (lb ft)	Nm (lb ft)	Nm (lb ft)
	P105	P111	P404	95A
X043	25 (18)	15 (11)	60 (44)	25 (18)

PUMP SIZE	END COVER		SUCTION CHAMBER / STATOR		SUCTION CHAMBER / BODY	BEARING COVER	FLEXISHAFT TIE BOLT
	Nm (lb ft.)		Nm (lb ft.)		Nm (lb ft.)	Nm (lb ft.)	Nm (lb ft.)
	P582	P581	P580	P527	P105	P111	P404
X054	60 (44)	60 (44)	60 (44)	60 (44)	40 (30)	15 (11)	95 (70)
X061	60 (44)	60 (44)	60 (44)	60 (44)	25 (18)	15 (11)	60 (44)
X062	60 (44)	60 (44)	60 (44)	60 (44)	40 (30)	15 (11)	95 (70)
X063	60 (44)	60 (44)	60 (44)	60 (44)	40 (30)	15 (11)	95 (70)
X071	60 (44)	60 (44)	60 (44)	60 (44)	40 (30)	15 (11)	95 (70)
X073	60 (44)	60 (44)	60 (44)	60 (44)	40 (30)	15 (11)	95 (70)
X074	60 (44)	60 (44)	60 (44)	60 (44)	90 (68)	15 (11)	95 (70)
X091	60 (44)	60 (44)	60 (44)	60 (44)	40 (30)	15 (11)	95 (70)
X093	60 (44)	60 (44)	60 (44)	60 (44)	90 (68)	15 (11)	95 (70)

#### **UK and Europe**

Mono Pumps Ltd, Martin Street, Audenshaw  
Manchester, M34 5JA, England  
T. +44 (0)161 339 9000  
E. info@mono-pumps.com

#### **Americas**

NOV Monoflo, 9606 Kirkton  
Houston, Texas 770495, USA  
T. +1 281 200 1200  
E. inquire@monoflo.com

#### **Monoflo SA**

Ing. Huergo 2239 - B1842GGW  
Monte Grande  
Buenos Aires  
Argentina  
T. +54 4296 8997  
F. +54 4284 0323  
E. inquire@monoflo.com

#### **Australasia**

Mono Pumps (Australia) Pty Ltd  
Mono House, 338-348 Lower Dandenong Road  
Mordialloc, Victoria 3195, Australia  
T. +61 (0)3 9580 5211  
E. ozsales@mono-pumps.com

Mono Pumps (New Zealand) Ltd  
PO Box 71-021, Fremlin Place, Avondale  
Auckland 7, New Zealand  
T. +64 (0)9 829 0333  
E. info@mono-pumps.co.nz

#### **Asia**

Mono Pumps Ltd, No. 500 YaGang Road  
Lujia Village, Malu, Jiading District  
Shanghai 201801, P.R. China  
T. +86 (0)21 5915 7168  
E. monoshanghai@nov.com

[www.mono-pumps.com](http://www.mono-pumps.com)



One Company, Unlimited Solutions